

DX SIDE X SIDE LX SIDE X SIDE STROLLER



INSTRUCTION MANUAL

11601
11701

ADULT ASSEMBLY REQUIRED
STYLES AND COLORS MAY VARY



⚠ WARNING:
CHOKING HAZARD

Adult assembly required because of small parts. Keep assembly parts out of reach of children under 3 years.

Read all instructions BEFORE assembly and USE of product
KEEP INSTRUCTIONS FOR FUTURE USE.

Customer Experience Center
phone: (646)-435-8726
email: gcs@DeltaChildren.com



www.DeltaChildren.com

DCP-IM-07122019-F9

WARNING

WARNING: Please follow all of these instructions to ensure the safety of your child.
Keep these instructions for future reference.

WARNING: Failure to follow these instructions could result in serious injury or death.

- Avoid serious injury from falling or sliding out. **ALWAYS** insure that the child is properly positioned by using the safety harness according to these instructions. **ONLY** children who have developed enough upper body control to sit without leaning forward can use the front seat in the upright position.
- **NEVER** leave children unattended.

WARNING: CHOKING HAZARD Adult assembly required because of small parts.
Keep (assembly parts) out of reach of children under 3 years.

CAUTION: Purses, shopping bags, parcels, diaper bags or accessory items may change the balance of the stroller and cause hazardous unstable conditions.

TO PREVENT INJURY

- Make sure all body parts are clear of the stroller when folding and unfolding.
- **DO NOT** place hot liquids in the cup holder. Hot liquids can burn your child.
- The maximum weight that can be carried in the lower basket, and child tray, each is 3 lbs (1.36 kg). Excessive weight may cause a hazardous unstable condition to exist.
- Before allowing the children near the stroller, be certain the stroller is fully erect and latched in the open locked position.
- Use of the stroller with children weighing more than 50 pounds (22.62 kg) or over 42 inches (106.7 cm) tall, may cause a hazardous unstable condition to the stroller.
- **NEVER** use the stroller on stairways or escalators.
- **NEVER** allow your stroller to be used as a toy.
- **NEVER** use the stroller in conjunction with bicycles, skateboards, roller skates, or in-line skates. Please discuss using the jogging stroller with your health care provider prior to jogging use. We recommend that the child occupant needs to be 6 months of age, at the minimum, before use of the stroller.

Product features and decorations may vary from the photo.

CARE AND MAINTENANCE

- To clean the plastic parts on stroller use a mild cleaning solution with warm water on a sponge or damp cloth. Hand wash fabric with damp cloth and air dry. Do not use bleach.
- To keep your stroller wheels from squeaking, use silicone or graphite based lubricant.
- Check your stroller for loose screws, worn parts, torn material or stitching on a regular basis. Replace or repair parts as needed, discontinue use of stroller if it should become damaged or malfunctions.



Before returning this product to the store! Let's see if we can assist you!

- **Not sure how to assemble our product?**

Visit our site for easy to follow instructions along with some Tricks and Tips assembly video's <https://www.deltachildren.com/pages/instructions>

- **If you are missing a piece or have a damaged part**

Please contact our Consumer Experience Center for assistance at 646-435-8726. To better assist you please have your Style #, Lot # and Manufacturer Date information available along with the part number that you need assistance with.

- **In the event we do not have a replacement part available**

You may need to return your product to the retailer for an exchange or refund.

- **Warranty**

In order to protect your investment, don't forget to register your product.

You may also wish to consider purchasing our extended warranty.

Visit <https://www.deltachildren.com/pages/extended-warranty> for more details.

- **Please note:**

“All Final”, “As Is” or Third Party/Liquidator sales are not covered under our Limited Limited Manufacturer Warranty..



LIMITED MANUFACTURER WARRANTY

This Delta product is warranted to be free from defects for a period of 90 days from the date of purchase under normal use. This warranty extends only to the original retail purchaser and is valid only when supplied with proof of purchase, or if received as a gift, when the registration is on file with Delta. This limited manufacturer warranty does not cover the following:

- Products purchased as floor models or samples.
- Items purchased on an “as-is” basis, as a second hand product, or as a resale product.
- Items purchased at a Final sale, a “Going out of Business” sale, or a Liquidation sale.

TO REGISTER YOUR PRODUCT for important safety alerts and updates to your product please visit www.deltachildren.com

TO REPORT A PROBLEM, please log on to www.deltachildren.com and click the Consumer Care Tab, or contact us by phone at 646-435-8726

Date of Purchase: _____ (you should also keep your receipt)



EXTENDED WARRANTY

DON'T MISS YOUR CHANCE TO BE COVERED FOR ALL OF LIFE'S MISHAPS!

With Delta's Extended Warranty, you're covered for mechanical failure from normal use or if your item stops working due to normal wear and tear, plus all those unexpected surprises.

2 YEARS OF PROTECTION

For Additional Information:

Simply visit our Website, register your product, and add the Extended Warranty

<https://www.deltachildren.com/pages/product-registration>

Extended Warranty only available in the following States: Arkansas, Colorado, Delaware, District of Columbia, Georgia, Idaho, Illinois, Indiana, Iowa, Kansas, Kentucky, Louisiana, Maryland, Michigan, Mississippi, Missouri, Nebraska, Nevada, New Hampshire, New York, North Carolina, North Dakota, Pennsylvania, Rhode Island, South Dakota, Tennessee, Utah, West Virginia

Parts

IMPORTANT! Please remove all parts from the package and identify them before assembly.

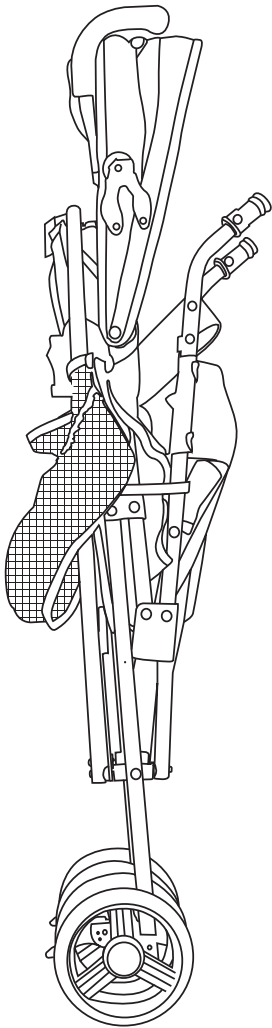

Stroller

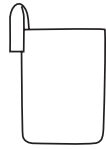

Cup Holder
Part# 17422

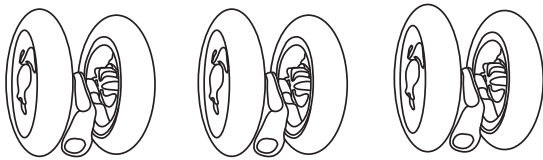

3 Front Wheel Assemblies
Part# 17421

Assembly

IMPORTANT! Before assembly or each use, inspect this product for damaged hardware, loose joints, missing parts or sharp edges. DO NOT use if any parts are missing or broken. Contact manufacturer for replacement parts and instructions if needed. Never substitute parts.

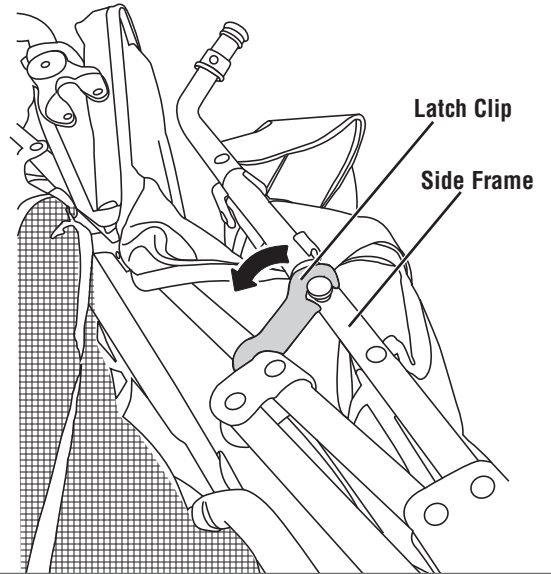

1

- Locate the latch clip on the side frame of the stroller.
- Pull to release the latch clip.

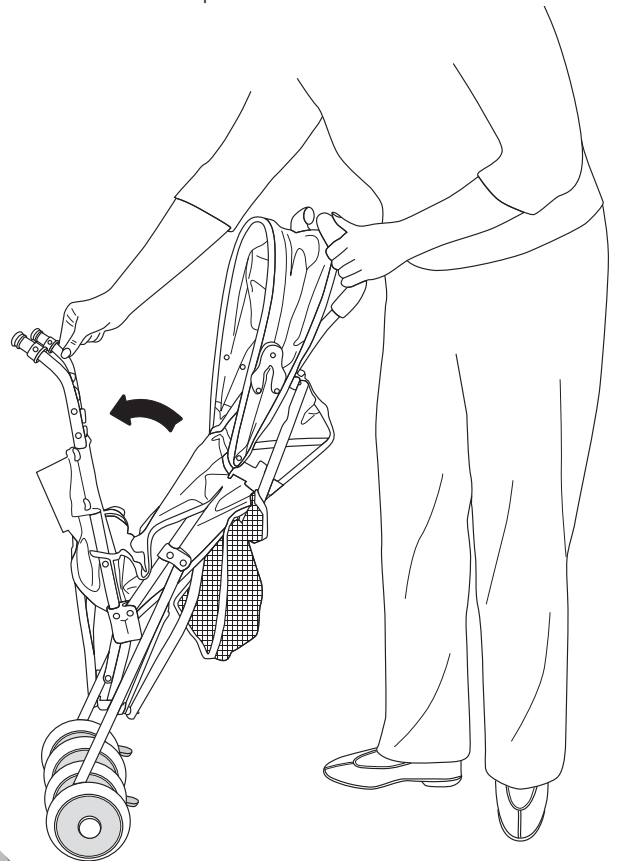

2

- Position the stroller upright on its rear wheels.
- Grasp a handle with one hand. With your other hand, push down on the front of the stroller to open.

Assembly

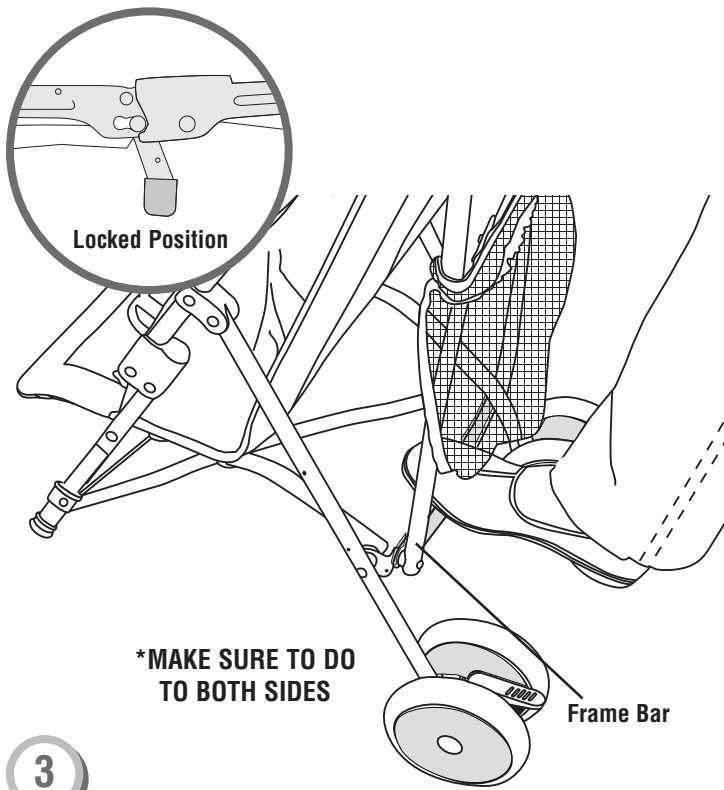

3

- With your foot, press down on the frame bar until it “clicks” into place.
- Check to be sure the stroller is locked open by pulling up on the frame bar.

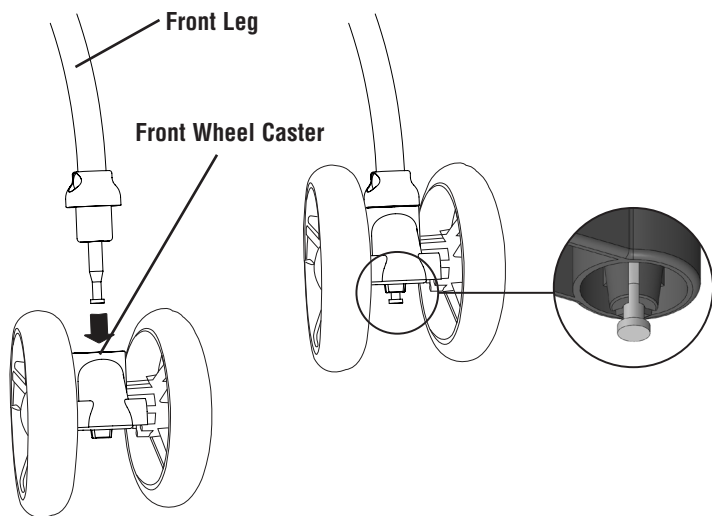

4

Front Wheel Assembly

- Slide the front wheel caster onto a front leg. Make sure you hear a “click”.
- Pull on the front wheel assembly to make sure it is securely attached to the front leg.
- Repeat this procedure to attach the other front wheel assemblies.

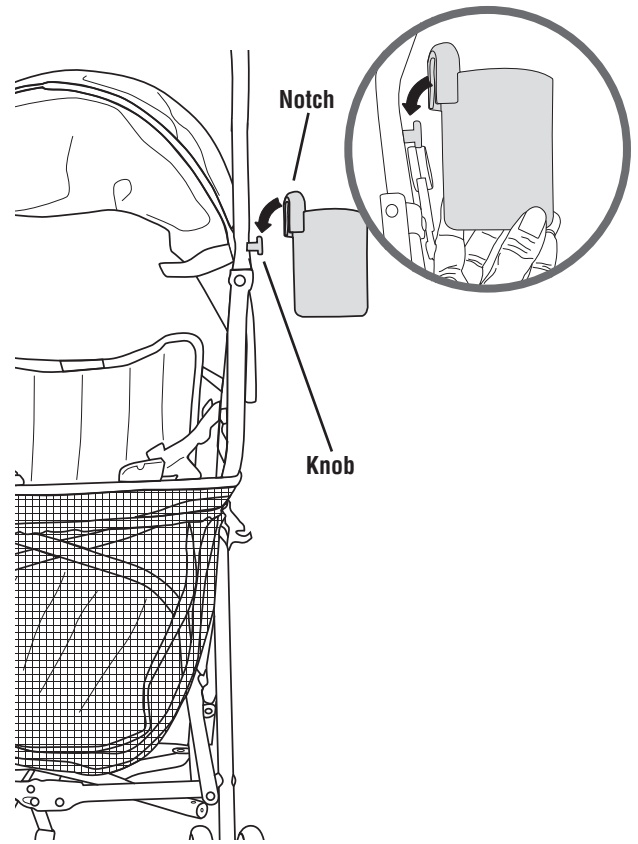

5

Attaching Cup Holder

- Locate the knob on the side of the stroller.
- Fit the notch in the cup holder over the knob on the side rail and push down until you hear a “click”. Pull up on the cup holder to be sure it is secure.

Setup and Use

WARNING

Prevent serious injury from falls or sliding out:

- ALWAYS use the restraint system.
- Only children who have developed enough upper body control to sit without leaning forward can use the front seat in the upright position.
- NEVER leave child unattended.
- DO NOT use the storage bag to carry children.

To prevent product from tipping over:

- DO NOT exceed the maximum storage weight limit of 3 lbs (1.36 kg) in the storage bag or canopy pouch.
- DO NOT exceed the maximum storage weight limit of 3 lbs (1.36 kg) in the cupholder.
- DO NOT place additional items on this product, except as recommended in the instructions.

To prevent injury:

- Make sure all body parts are clear of the stroller when folding and unfolding.
- DO NOT place hot liquids in the cup holder. Hot liquids can burn your child.

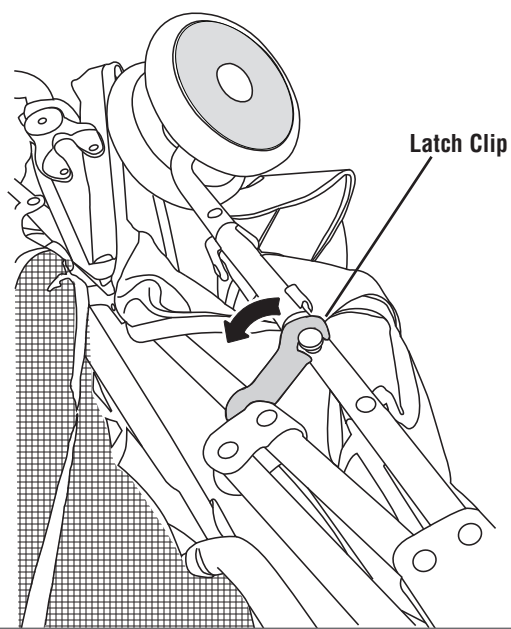

1

To Unfold

- Locate the latch clip on the side of the stroller.
- Pull to release the latch clip on the side of the stroller.

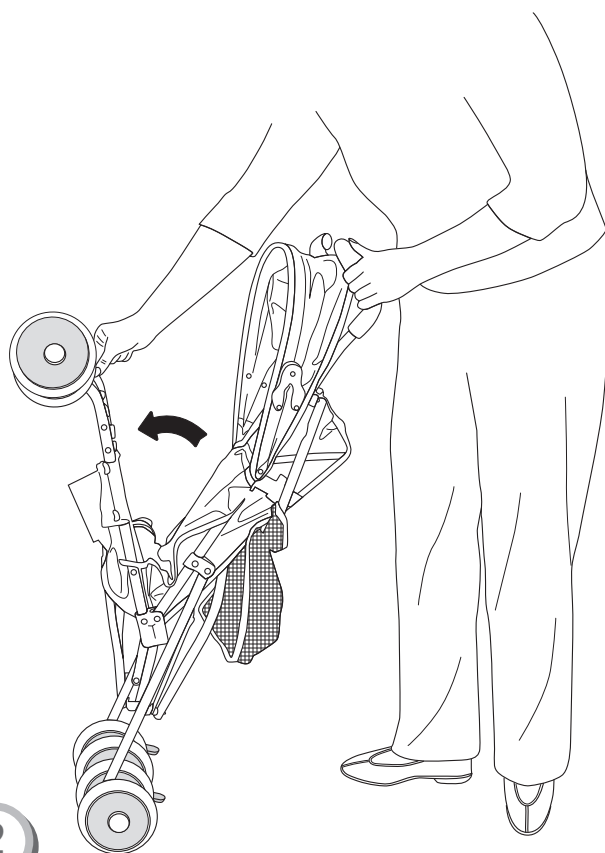

2

- Grasp a handle with one hand. With your other hand, push down on the front leg. Pull the stroller apart.

Setup and Use

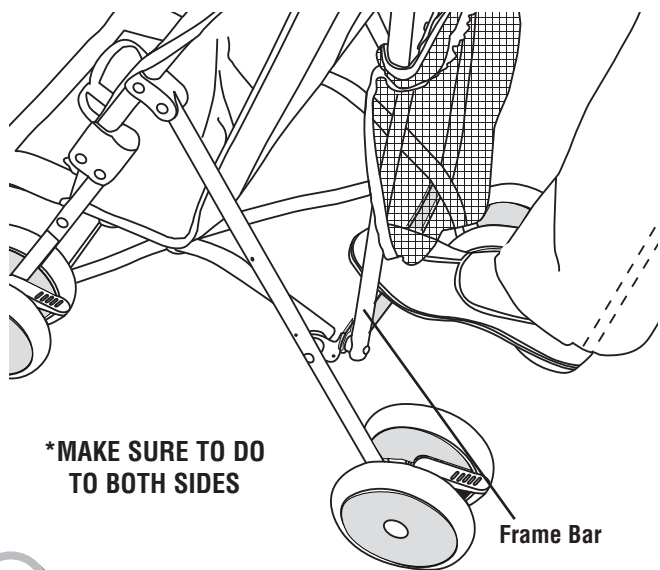

***MAKE SURE TO DO TO BOTH SIDES**

3

- With your foot, press down on the frame bar until it “clicks” into place.
- Pull up on the frame bar to make sure it is locked.

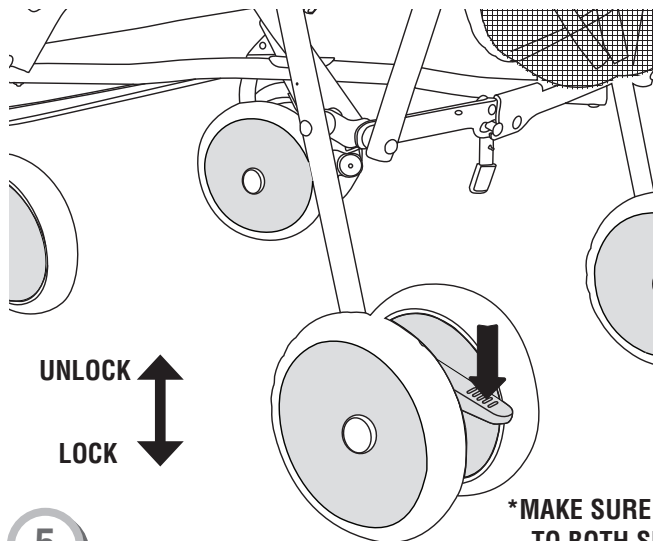

***MAKE SURE TO DO TO BOTH SIDES**

5

Rear Wheel Brakes

To lock the rear wheel brakes:

- Press **both** brake pedals down until they “click” into the locked position. **Make sure the brake pedals are pressed down completely.**
- Always set both brake pedals whenever you park the stroller.

To unlock the rear wheel brakes:

- Lift both brake pedals until they “click” into the unlocked position.

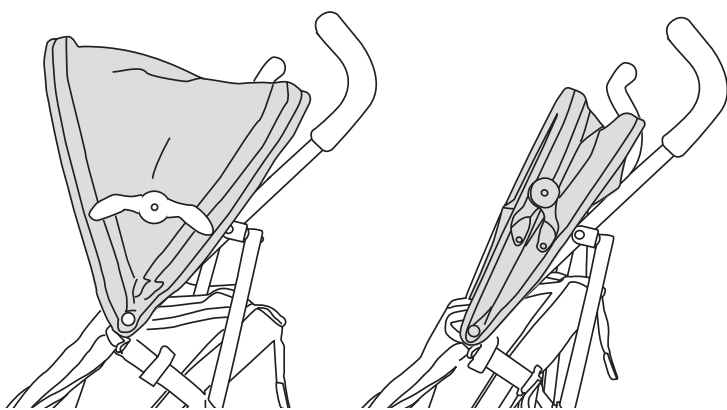

4

CANOPY OPEN

CANOPY CLOSED

Canopy Adjustment

- The canopy can be adjusted to the open or closed position.

Securing Child

Before Placing your Child in Stroller: Close Canopy. Press both brake pedals down until they “click” into the locked position. **Make sure the brake pedals are pressed down completely.** Always set both brake pedals when parking the stroller.

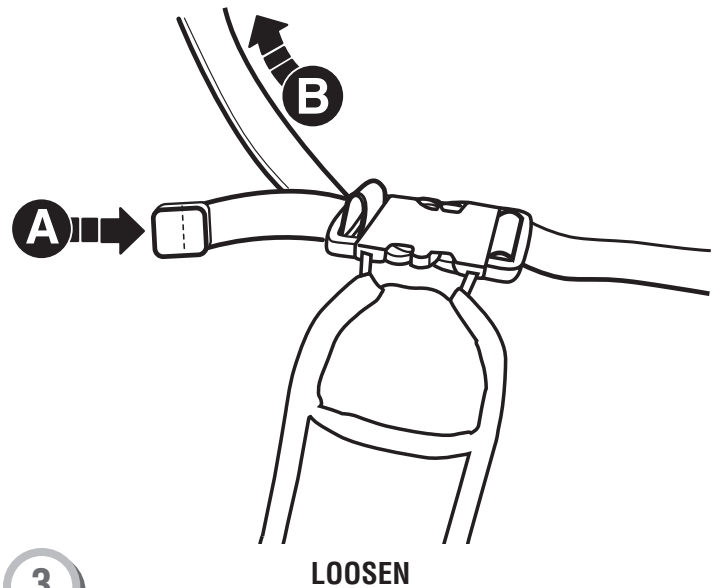
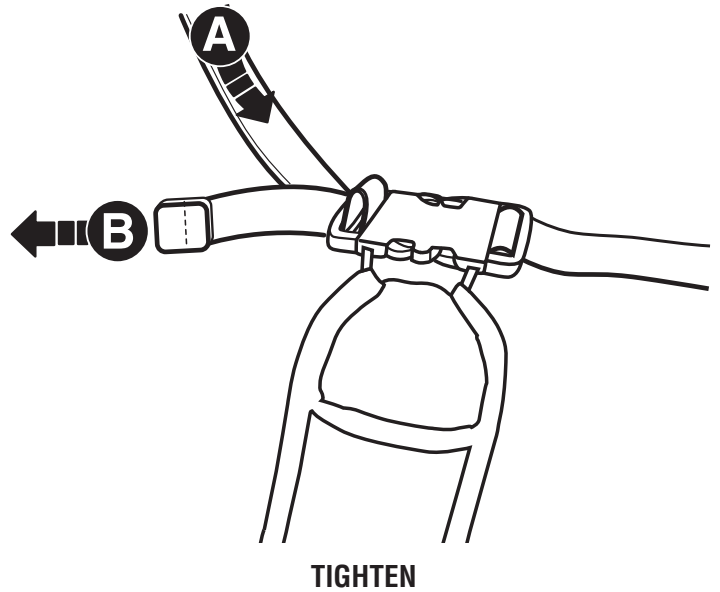
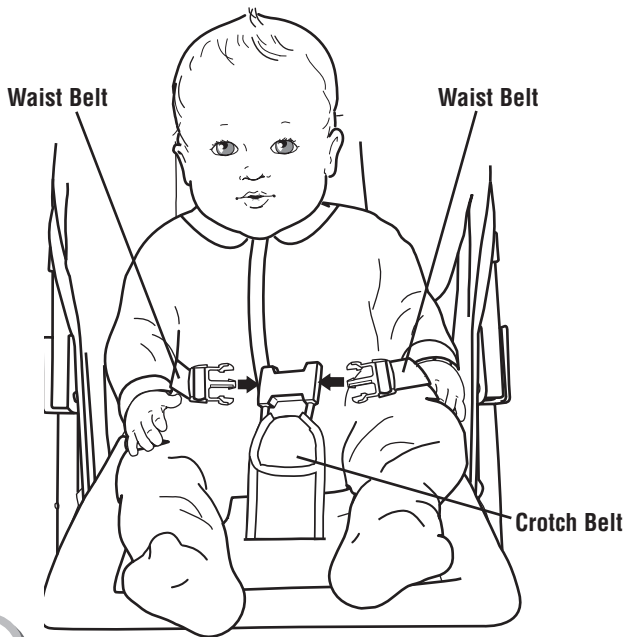

1

Securing Child

- Place your child in the stroller. Position the crotch belt between your child's legs.
- Fasten **both** waist belts to the buckle on each side of the crotch belt. Make sure you hear a “click” on both sides.
- Check to be sure the restraint system is securely attached by pulling it away from your child. The restraint system should remain attached.

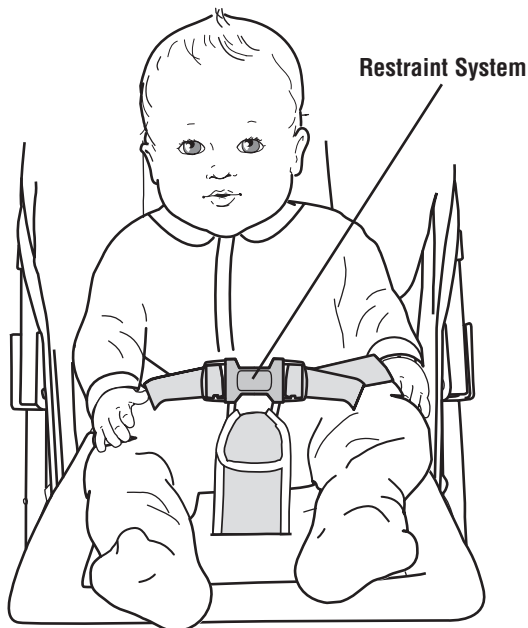

2

- Tighten each waist belt so that the restraint system is snug against your child. Please refer to the next section for instructions to tighten the waist belts.

3

To tighten the waist belts:

- Feed the anchored end of a waist belt up through the buckle to form a loop **A**. Pull the free end of the waist belt **B**.
- Repeat this procedure to tighten the other waist belt.

To loosen the waist belts:

- Feed the free end of the waist belt up through the buckle to form a loop **A**. Enlarge the loop by pulling on the end of the loop toward the buckle. Pull the anchored end of the waist belt to shorten the free end of the waist belt **B**.
- Repeat this procedure to loosen the other waist belt.

Please note: After adjusting the restraint system to fit your child, make sure you pull on it to be sure it is securely fastened.

Storage

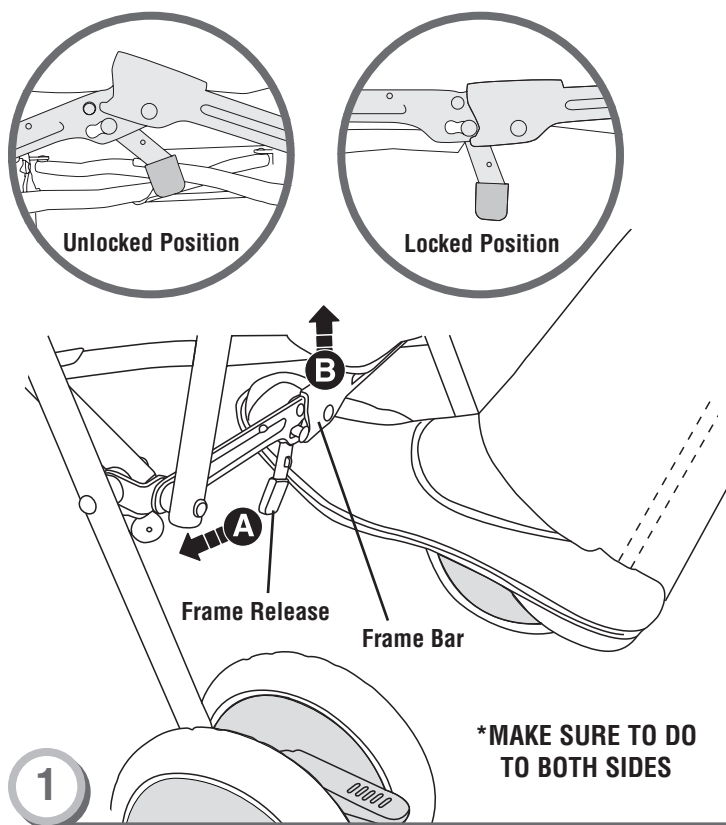

***MAKE SURE TO DO TO BOTH SIDES**

Hint: Make sure canopy is in the closed position before folding the stroller.

- With your foot, slide the frame release to the left **A**, then push up on the frame bar **B**.

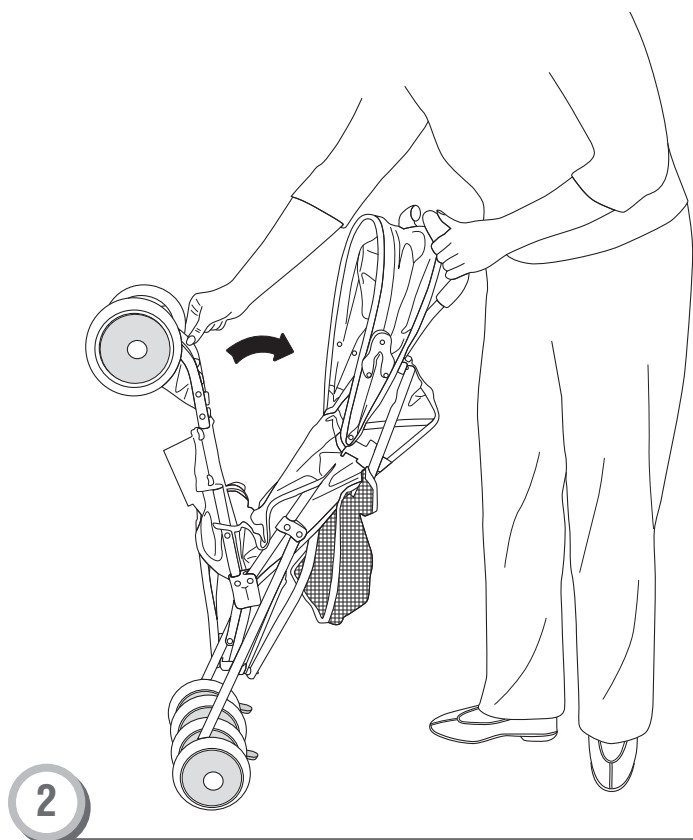

- Lift the front wheels toward the closed canopy.

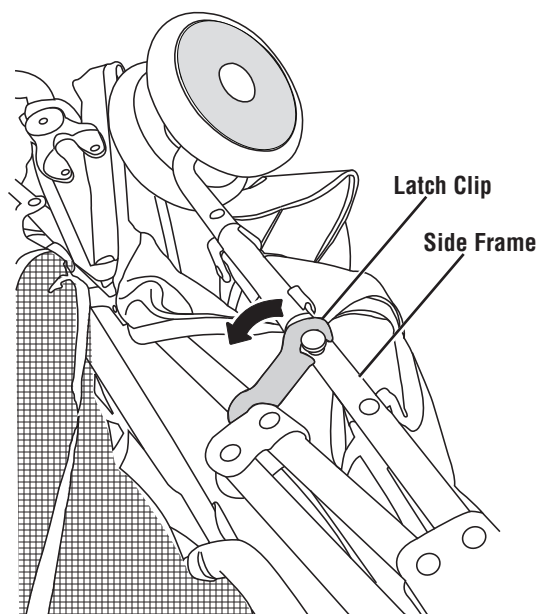

- Slide the latch clip onto the side frame to secure in the folded storage position.



Delta Children's Products Corp.

114 West 26th Street
New York, NY 10001
646-435-8726
www.DeltaChildren.com